

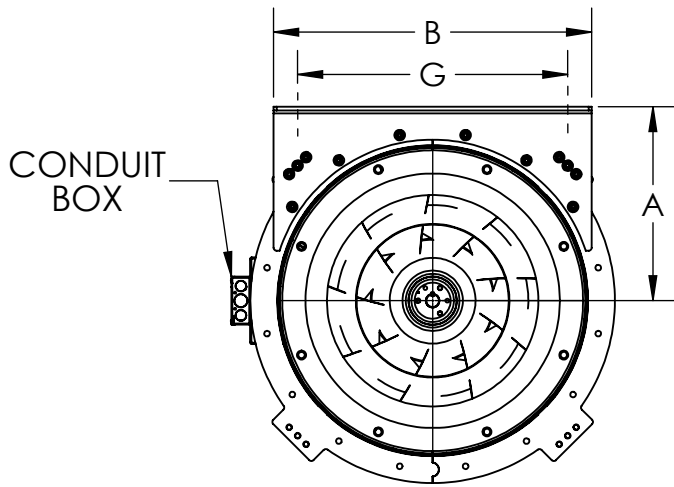

DATE: TAG:
 JOB:
 PROJECT:
 COMPANY:
 SALES PERSON:

MXI-ARRANGEMENT- 4, LEVEL 2,
 HORIZONTAL CEILING HUNG



INLET VIEW

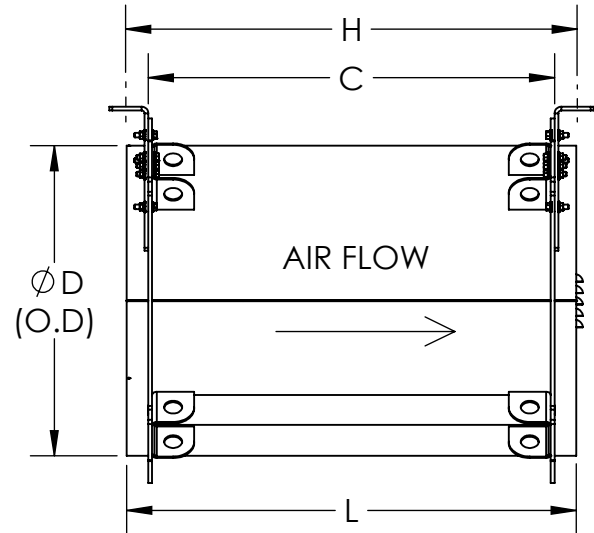

Standard Construction:

1. High Efficiency Welded Mixed Flow Wheel
2. Welded Guide Vanes
3. Extended Lube Lines
4. Motor Tunnel
5. Bolted Mounting Feet

Accessories:

1. AMCA B Spark Resistant Construction
2. AMCA C Spark Resistant Construction
3. Mounting Rails
4. Vibration Isolators
5. Piezo Ring
6. Disconnect Switch

7. Access Door- Hinged or Bolted
8. Copper Lube Lines
9. Inlet and/or Outlet Flange
10. Inlet and/or Outlet Guard
11. Companion Flange
12. Drain
13. Flexible Duct Connector
14. VFD

DIMENSIONAL DATA

Size	A	B	C	D	G	H	L	MAX MOTOR FRAME SIZE	MXI FAN WEIGHT (LESS MOTOR) (LBS)	MXI-AF FAN WEIGHT (LESS MOTOR) (LBS)
122	12 11/16	20 13/16	21 1/2	17 3/4	16 13/16	25 1/4	25 1/8	145T	180	181
135	14	22 1/8	24 3/16	19 5/8	18 1/8	27 15/16	27 13/16	145T	214	213
150	14 3/4	23 11/16	27 1/4	21 13/16	19 11/16	31 1/16	30 7/8	145T	250	254
165	15 5/16	24 3/4	30 3/8	23 5/16	20 3/4	34 1/8	33 15/16	184T	285	290
182	16 3/16	26 1/2	33 7/8	25 11/16	22 1/2	37 5/8	37 7/16	215T	352	357
200	17 1/16	28 5/16	37 9/16	28 1/4	24 5/16	41 5/16	41 3/16	256T	426	430
222	19 5/8	32 1/8	42 1/16	31 5/16	27 1/8	45 13/16	45 11/16	256T	535	528
245	20 7/8	34 7/16	46 13/16	34 9/16	29 7/16	52 1/16	50 7/16	286T	636	632
270	22 1/8	36 15/16	51 15/16	38 1/16	31 15/16	57 1/4	55 9/16	326T	762	771
300	24 3/4	40 5/8	58 1/8	42 1/4	35 5/8	63 7/16	61 3/4	326T	937	927
330	26 1/4	43 5/8	64 3/8	46 1/2	38 5/8	69 5/8	68	365T	1090	1102
365	29	47 5/8	71 1/2	51 7/16	42 1/8	77 1/16	75 1/8	404T	1337	1334
402	31 7/8	51 5/16	79 1/8	56 5/8	45 13/16	84 11/16	82 3/4	404T	1591	1549
445	34 5/16	56 5/16	88	62 5/8	50 13/16	93 1/2	91 5/8	405T	1879	1825
490	38 1/2	63 3/4	97 1/4	69	56 1/4	104 1/4	100 7/8	444T	2451	-
542	41 7/16	69 5/8	107 15/16	76 1/4	62 1/8	115	111 9/16	445T	2903	-
600	46 1/2	76 3/8	119 7/8	84 7/16	67 3/16	126 15/16	123 1/2	445T	3482	-

ALL DIMENSIONS ARE IN INCHES

REVISION:

FORM:

REPLACES: